

GR716-MINI User's Manual

Dec 2024, Version 1.1

TABLE OF CONTENTS

1	Introduction	4
1.1	Scope and Purpose of the Document	4
1.2	Reference Documents	4
2	Abbreviations	5
3	Introduction	6
3.1	Overview	6
3.2	Handling	7
4	Board Design	8
4.1	Board Block Diagram	8
4.2	Board Mechanical Configuration	9
4.3	GR716 Microcontroller	10
4.4	Memory	11
4.5	Expansion/Interface Connector	12
4.6	LVDS Interfaces	13
4.7	FTDI Serial to USB Interface	15
4.8	Analog Signals	16
4.9	GPIO	17
4.10	Bootstrap Signals	18
4.11	Debug Support Unit Interfaces	19
4.12	Oscillators and Clock Inputs	20
4.13	Power Supply and Voltage Regulation	21
4.14	Reset Circuit and Button	22
4.15	Watchdog	22
5	Setting Up and Using the Board	23
6	Interfaces and Configuration	24
6.1	List of Connectors	24
6.2	List of Oscillators, Switches and LED's	26

List of Figures

Figure 3-1: GR716-MINI Development Board.....	6
Figure 4-1: GR716-MINI Board Block Diagram.....	8
Figure 4-2: GR716-MINI Board Dimensions (top side)	9
Figure 4-3: GR716-MINI Board Dimensions (bottom side - expansion connector)	9
Figure 4-5: GR716 Microcontroller Block Diagram	10
Figure 4-6: GR716 Package	11
Figure 4-7: SPI Boot Memory Connection	11
Figure 4-8: SRAM Signal Connections	12
Figure 4-9: Expansion/Interface Connector	13
Figure 4-10: Block diagram of FTDI Serial to USB Interface.....	15
Figure 4-11: MMCX analog connector interface.....	16
Figure 4-12: Debug Support Unit connections	19
Figure 4-13: Board level Clock Distribution Scheme.....	20
Figure 4-14: Power Regulation Scheme	21
Figure 6-1: PCB Top View.....	27
Figure 6-2: PCB Bottom View	27
Figure 6-3: PCB Top View (Photo).....	28
Figure 6-4: PCB Bottom View (Photo)	28

List of Tables

Table 1: List of Expansion Connector signals	13
Table 2: FTDI USB-Serial Port Assignment.....	15
Table 3: List of GPIO pins connected to Expansion Connector.....	17
Table 4: Bootstrap Resistor Settings.....	18
Table 5: Default Setting of Jumpers	23
Table 6: List of Connectors	24
Table 7: J1 USB type Micro B connector – FTDI Serial Link.....	24
Table 8: J2,J3,J4,J5 MMCX miniature coax connectors	24
Table 9: Expansion connector P1 Pin-out	25
Table 10: List and definition of Oscillators and Crystals.....	26
Table 11: List and definition of PCB mounted LED's	26
Table 12: List and definition of Switches	26

1 INTRODUCTION

1.1 Scope and Purpose of the Document

This document provides a User's Manual and Interface document for the "GR716-MINI" Development and Demonstration board.

The work has been performed by Frontgrade Gaisler AB, Göteborg, Sweden.

1.2 Reference Documents

- [RD1] GR716, Data Sheet and User's Manual", Frontgrade Gaisler, GR716-UM-DS, available from <http://www.gaisler.com/index.php/products/components/GR716>
- [RD2] GR716-MINI_schematic.pdf, Schematic
- [RD3] GR716-MINI_assy_drawing.pdf, Assembly Drawing
- [RD4] GRMON3 User's Manual, available from:
<https://www.gaisler.com/index.php/products/debug-tools/grmon3>

2 ABBREVIATIONS

ASIC	Application Specific Integrated Circuit.
DSU	Debug Support Unit
EDAC	Error Detection and Correction
ESA	European Space Agency
ESD	Electro-Static Discharge
ESTEC	European Space Research and Technology Center
GPIO	General Purpose Input / Output
IC	Integrated Circuit
I/O	Input/Output
IP	Intellectual Property
LDO	Low Drop-Out
PCB	Printed Circuit Board
POL	Point of Load
SOC	System On a Chip
SPW	Spacewire
TBC	To Be Confirmed
TBD	To Be Defined

3 INTRODUCTION

3.1 Overview

This document describes the GR716-MINI Development Board.

This equipment is intended to be used as a platform for the demonstration of the Frontgrade Gaisler GR716 RAD Hard Microcontroller.

Furthermore, this board provides developers with a convenient hardware platform for the evaluation and development of software for the GR716 microcontroller.

The GR716 Microcontroller features a fault-tolerant LEON3 SPARC V8 processor, communication interfaces and on-chip ADC, DAC, Power-on-Reset, Oscillator, Brown-out detection, LVDS transceivers, regulators to support for single 3.3V supply, ideally suited for space and other high-rel applications.

Because not all features of the GR716 can be simultaneously operated, the GR716-MINI Development Board comprises a custom designed PCB providing a compact implementation with a representative array of interfaces and features.

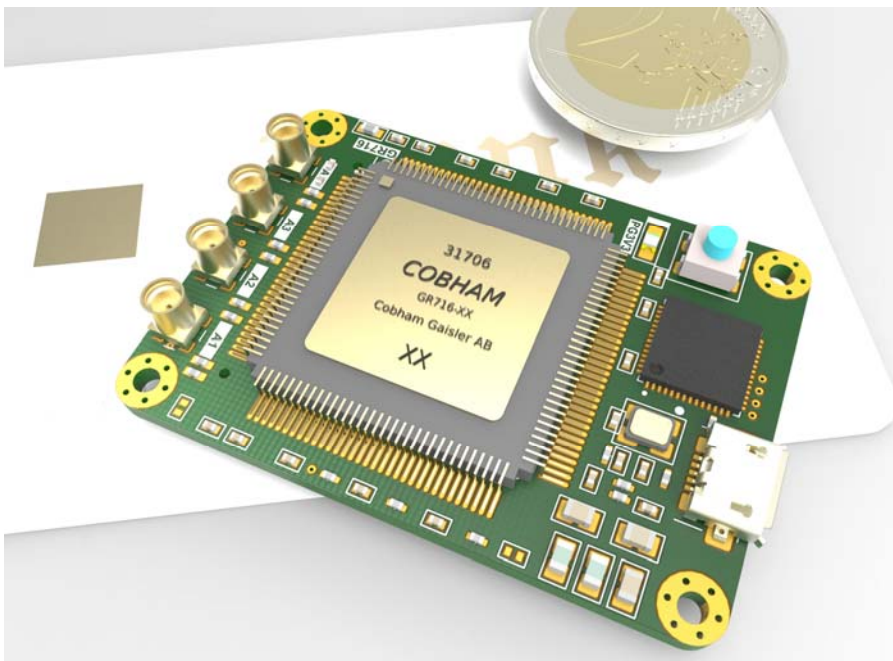

Figure 3-1: GR716-MINI Development Board

The board contains the following main items as detailed in section 4 of this document:

- size 35 x 50mm
- USB interface via FTDI FT4232 providing DSU plus 2 x UART
- on-board regulator converting from USB 5V to 3.3V.
- 16 Mbit SRAM (Cypress CY7C1069G in BGA package)
- 256 Mbit SPI flash (MX25L25635FZ2I-10G in 8 pin WSON package)
- On board crystal (25MHz TBC)
- 4 x MMCX coax connectors for 4x ADC or 4x DAC (or combination)
- Miniature 80 pin Expansion connector (bottom side) with connections for
 - Reset_IN & Reset_OUT
 - External SPW and SYS clocks
 - Vref_Buf_out
 - 3 x LVDS RX + 3 x LVDS TX pairs
 - Analog 4 x DAC + 8 x ADC (or use as standard 12 x GPIO)
 - 13 GPIO

Debug interface support is demonstrated on the board with support for debugging via the following interface:

- DSU-UART via FTDI USB interface

3.2 Handling



ATTENTION: OBSERVE PRECAUTIONS FOR HANDLING ELECTROSTATIC SENSITIVE DEVICES

This unit contains sensitive electronic components which can be damaged by Electrostatic Discharges (ESD). When handling or installing the unit observe appropriate precautions and ESD safe practices.

When not in use, store the unit in an electrostatic protective container or bag.

When configuring the jumpers on the board, or connecting/disconnecting cables, ensure that the unit is in an un-powered state.

When operating the board in a 'stand-alone' configuration, the power supply should be current limited to prevent damage to the board or power supply in the event of an over-current situation.

This board is intended for commercial use and evaluation in a standard laboratory environment, nominally, 20°C. All devices are standard commercial types, intended for use over the standard commercial operating temperature range (0 to 70°C).

4 BOARD DESIGN

4.1 Board Block Diagram

The GR716-MINI Board provides the electrical functions and interfaces as represented in the block diagram, Figure 4-2.

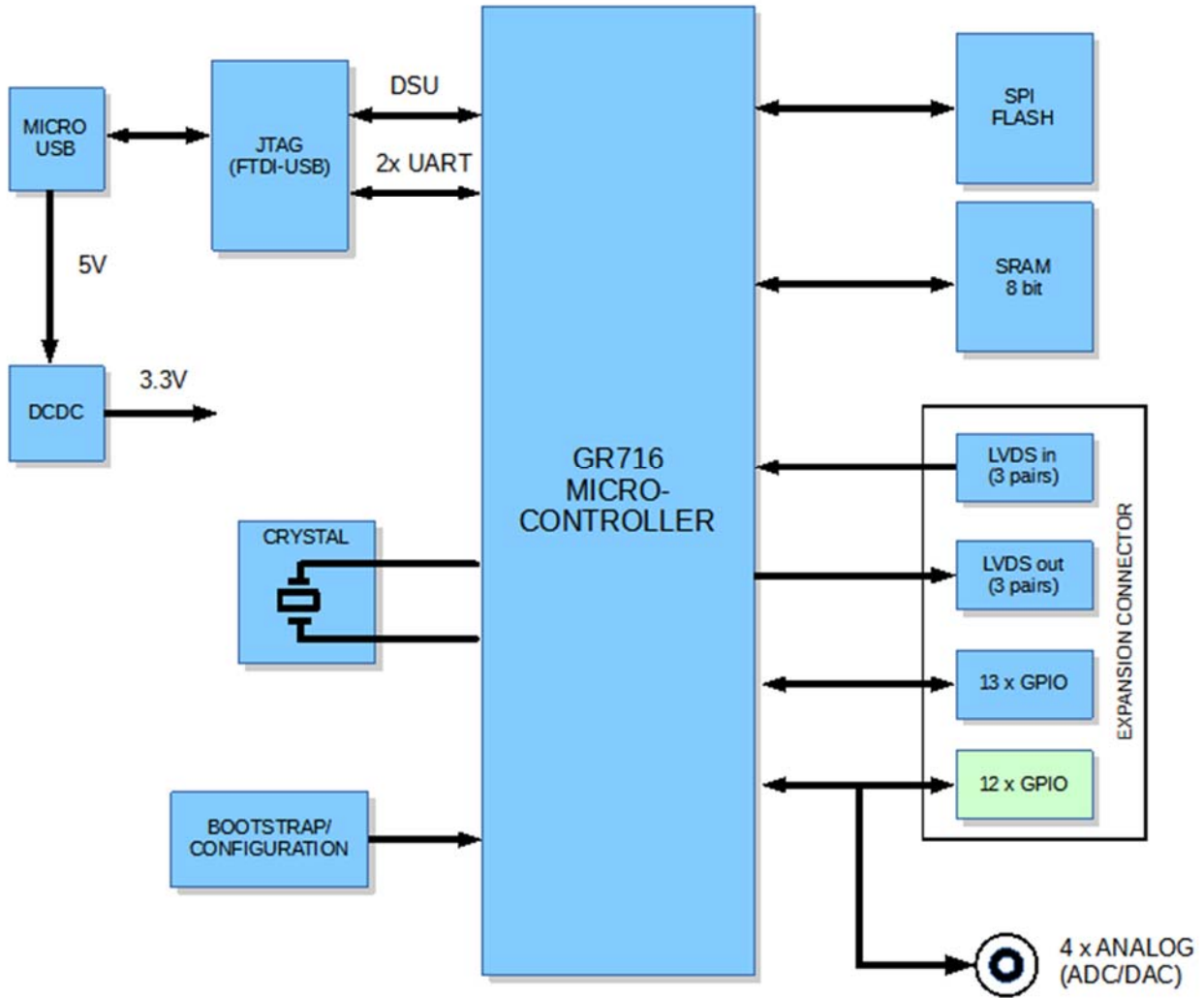

Figure 4-1: GR716-MINI Board Block Diagram

Note that not all features and interfaces are available at the same time, and the configuration of on-board resistors plus programming of registers is required to access some of the features.

4.2 Board Mechanical Configuration

The board (50 x 35mm) and can be used 'stand-alone' on the bench-top simply using an external USB cable as the main communication and power interface (+5V).

For mounting of the board on a carrier or expansion board, four M2 mounting holes are provided in the corners of the board, as shown in the figure below.

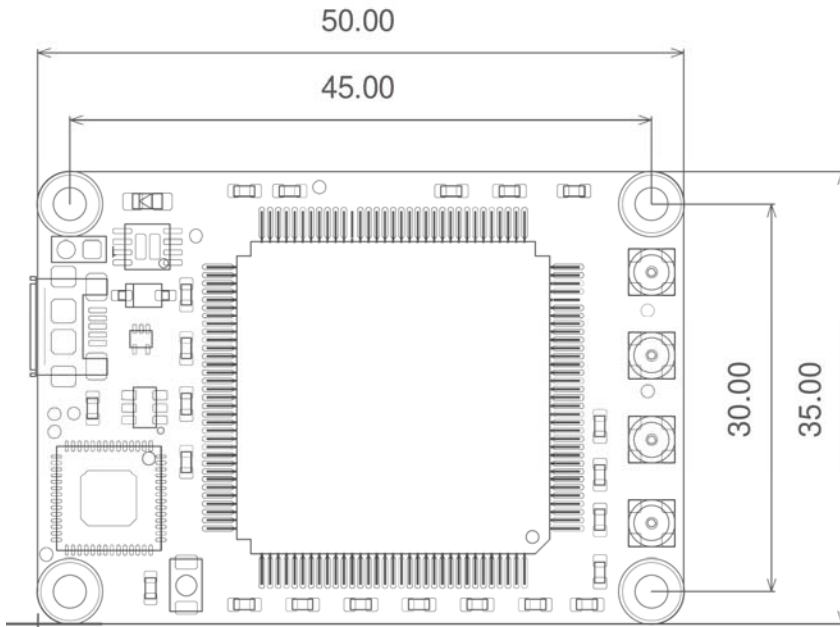

Figure 4-2: GR716-MINI Board Dimensions (top side)

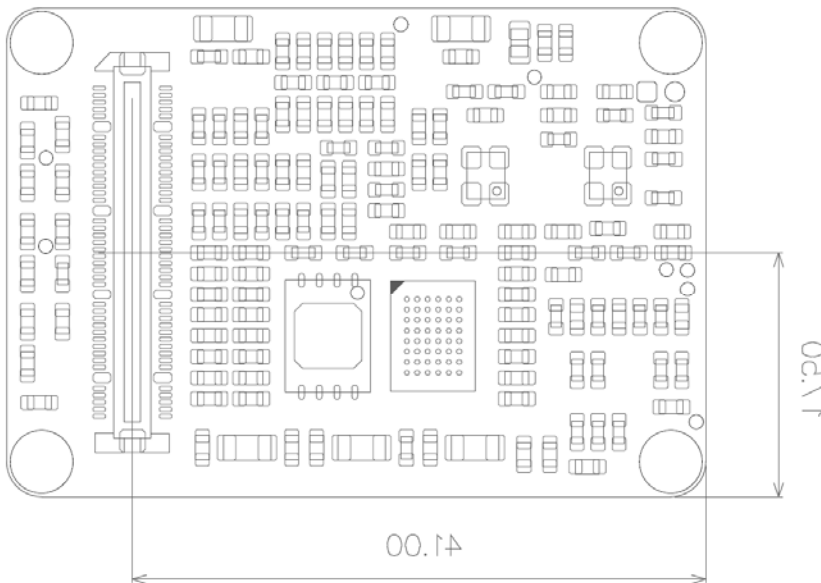

Figure 4-3: GR716-MINI Board Dimensions (bottom side - expansion connector)

4.3 GR716 Microcontroller

The Frontgrade Gaisler GR716 Microcontroller features a fault-tolerant LEON3 SPARC V8 processor, communication interfaces and on-chip ADC, DAC, Power-on-Reset, Oscillator, Brown-out detection, LVDS transceivers, regulators to support for single 3.3V supply, ideally suited for space and other high-rel applications.

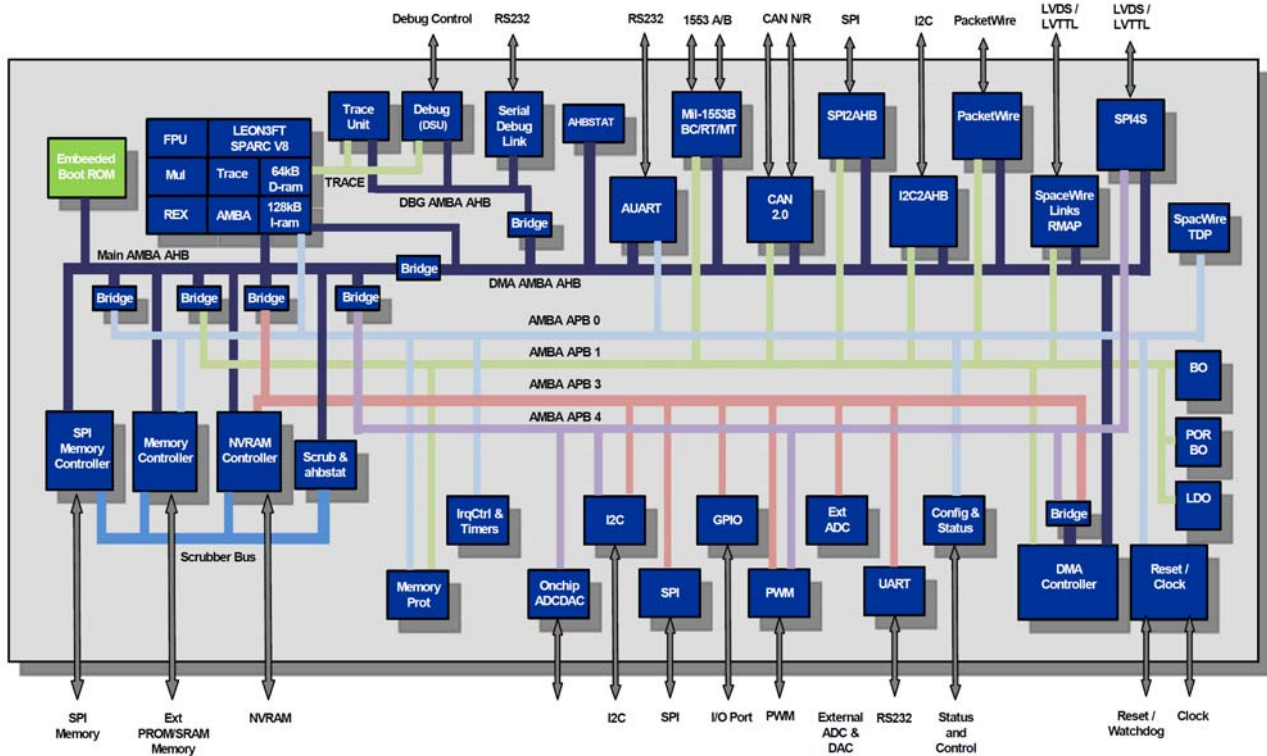

Figure 4-4: GR716 Microcontroller Block Diagram

The GR716 Microcontroller is a complex device with many modes of operation. For the details of the interfaces, operation and programming, refer to [RD1].

The GR716 microcontroller is packaged in a 132-pin, 0.635mm pitch Ceramic Quad Flat Pack package (housing: 24 x 24 mm).



Figure 4-5: GR716 Package

4.4 Memory

The memory configuration installed on the board comprises:

- 256 Mbit SPI serial boot prom (MX25L25635FZ2I-10G))
- Mbit SRAM, 8 bit wide (CY7C1069G30)

The SPI boot memory is connected directly to the SPIM interface of the GR716 Microcontroller. Although the SPI memory can operate in a x4 data mode, on this board, only a x1 data mode is used.

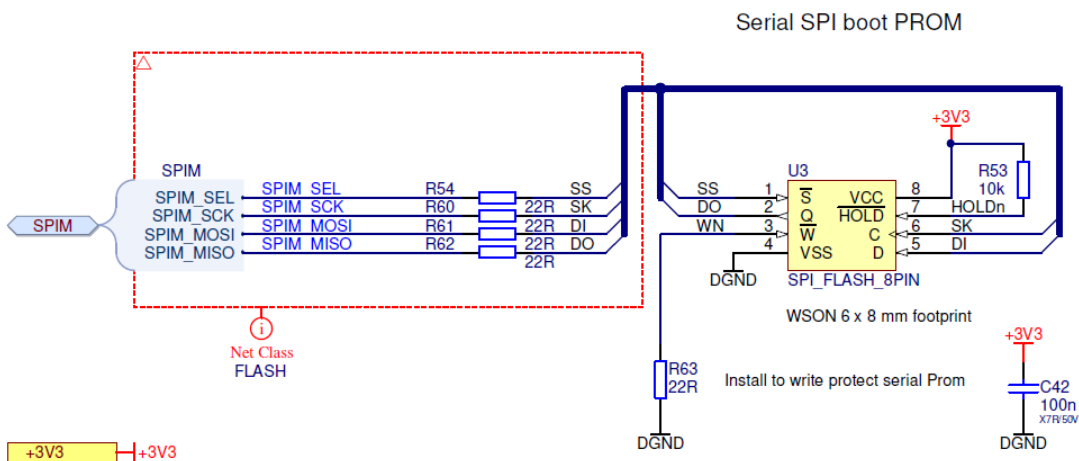

Figure 4-6: SPI Boot Memory Connection

The SRAM is connected to the GR716 Microcontroller using the GPIO[50..49], GPIO[34..0], GPIO[18..0] signals as shown in the figure below.

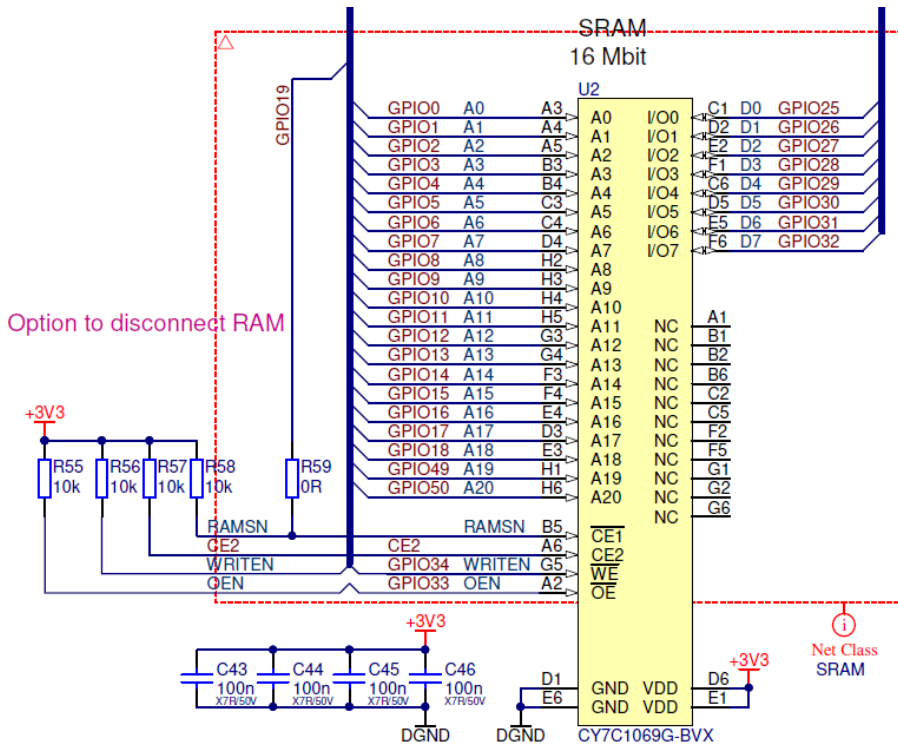

Figure 4-7: SRAM Signal Connections

4.5 Expansion/Interface Connector

To allow connection to external circuits, the bottom side of the board includes an 80 pin low-profile expansion connector.



Figure 4-8: Expansion/Interface Connector

The connector pin out and type are listed in section 6.1 and the signals include:

EXT_CLK	External 3.3V CMOS oscillator input for the main system clock, as alternative to the on-board generated 20MHz clock
EXT_SPWCLK	External 3.3V CMOS oscillator input for the Spacewire clock, as alternative to the on-board generated 20MHz clock
3 x LVDS_IN pairs	3 LVDS input pairs, configurable acc section 4.6
3 x LVDS_OUT pairs	3 LVDS input pairs, configurable acc section 4.6
RESET_IN	External input to reset circuit in GR716
RESET_OUT	Output from reset circuit in GR716 for external use
VREF_BUF	Buffered reference voltage output (1.000V nom.)
25 x GPIO	(up to) 25 General purpose I/O signals, acc section 4.9
3.3V input	Power input for external supply, acc section 4.13

Table 1: List of Expansion Connector signals

4.6 LVDS Interfaces

The GR716 microcontroller provides a set of three LVDS input pairs and 3 LVDS output pairs which are configurable from software via configuration registers to provide

SpaceWire or SPI4SPACE interfaces.

These signals are connected from the GR716 microcontroller to the Expansion connector.

100 Ohm Termination resistors and fail-safe resistors for the LVDS receiver signals are mounted on the board close to the receiver.



This equipment has Low Voltage Differential Signalling (LVDS) ports which has limited common mode voltage protection. To avoid damage to the LVDS interfaces due to common mode voltage the following actions should be performed before the equipments that will be connected by LVDS are powered on.

- Before connecting any LVDS cables, make sure that there is no voltage difference between the different equipment grounds. E.g., measure the voltage between the different equipment grounds with a voltmeter. The result should be close to 0 V.
- After the LVDS cables are connected, make sure that the equipment grounds are low ohmic connected to each other. E.g., measure the resistance between the different equipment grounds with a multimeter in resistance mode. The result should be less than 1 Ω .

This board is intended to be used stand alone or together with a carrier board. Users using the board stand alone or design their own carrier board, must ensure that equipments connected via LVDS have grounds that are connected together.

4.7 FTDI Serial to USB Interface

The GR716-MINI board provides an FTDI FT4232HL Serial to USB interface chip which provides up to 4 serial ports which connect to a single Micro-B USB connector (J1). This USB port can be connected to a host computer to allow communication over serial interfaces to Host PC's which do not have conventional 9 pin D-sub type RS232 connectors.

On this board, the port assignment is as follows:

Pin	Function	Alternative signal
A-port	DSU serial interface (DSURX, DSUTX)	-
B-port	Not assigned	-
C-port	UART port 2 (RXD, TXD, CTSN, RTSN)	GPIO[59..56]
D-Port	UART port 3 (RXD, TXD, CTSN, RTSN)	GPIO[61..63]

Table 2: FTDI USB-Serial Port Assignment

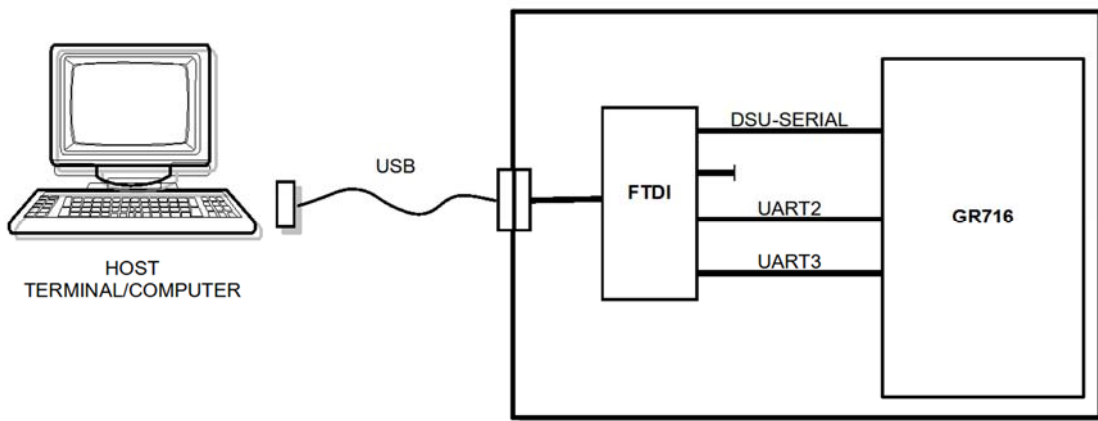

Figure 4-9: Block diagram of FTDI Serial to USB Interface

4.8 Analog Signals

The GR716-MINI board provides four micro-miniature (MMCX) coaxial connectors to allow access to up to 4 ADC inputs or 4 DAC outputs of the GR716 microcontroller.

As shown in Figure 4-11, depending on which resistors are installed, each MMCX connector can be either an ADC input or a DAC output.

Access to the ADC/DAC configurable from software via configuration registers, and for further information please refer to [RD1]

The nominal input range for the ADC inputs is 0 – 2.0V

The DAC outputs are current outputs with a full-scale range of 0 – 4mA.



No current limiting or overvoltage protection components are included on the GPIO/Analog signals of the GR716-MINI board. The signals are connected directly from the microcontroller to the coaxial/expansion connector. Care must therefore be taken to ensure that any external circuitry connected does not exceed the allowable voltage limits for the input/output pins.

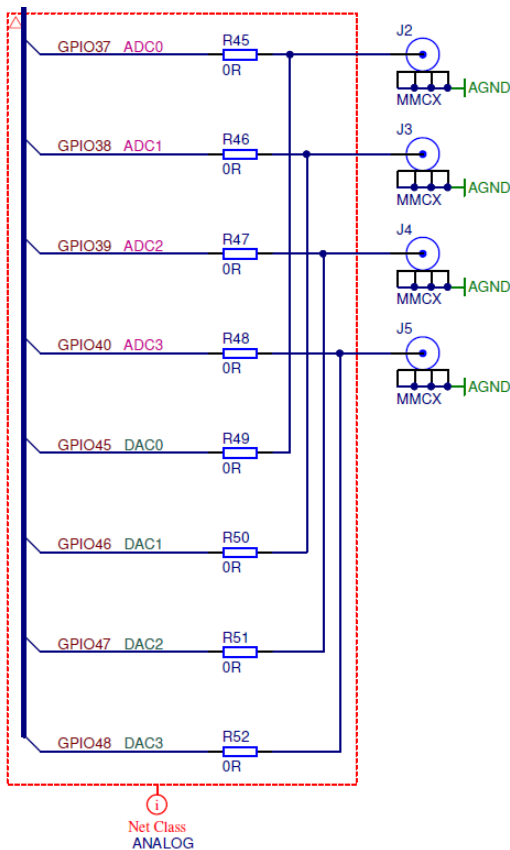

Note:
 As shown with all resistors fitted, the SMA connectors are DAC outputs and these are connected back to the ADC inputs.
 If a different configuration is required (e.g. 4 ADC inputs from external sources), then the appropriate resistors have to be removed

Figure 4-10: MMCX analog connector interface

4.9 GPIO

A total of 25 GPIO pins are connected from the GR716 Microcontroller to the Expansion connector. These General purpose I/O pins are 3.3V LVCMOS voltage levels. The following GPIO pins are connected.

Pin	Alternative function
GPIO55	-
GPIO54	-
GPIO53	-
GPIO52	-
GPIO51	-
GPIO48	DAC3
GPIO47	DAC2
GPIO46	DAC1
GPIO45	DAC0
GPIO44	ADC7
GPIO43	ADC6
GPIO42	ADC5
GPIO41	ADC4
GPIO40	ADC3
GPIO39	ADC2
GPIO38	ADC1
GPIO37	ADC0
GPIO36	-
GPIO35	-
GPIO24	-
GPIO23	-
GPIO22	-
GPIO21	-
GPIO20	-
GPIO19	-

Table 3: List of GPIO pins connected to Expansion Connector

Note: that some pins have a dual function and can be used instead as ADC or DAC signals. Care must be taken to account for this.



No current limiting or overvoltage protection components are included on the GPIO signals of the GR716-MINI board. The signals are connected directly from the microcontroller to the expansion connector. Care must therefore be taken to ensure that any external circuitry connected does not exceed the allowable voltage limits for the input/output pins.

4.10 Bootstrap Signals

A number of features of the GR716 microcontroller are required to be set at power-on of the processor, by means of bootstrap pins. A number of GPIO and function pins are pre-defined for this purpose.

Either the pull-up or the pull-down resistor should be installed to defined the desired setting, according the definition Table 22 of [RD1].

Pin	Function	Pull-up '1'	Pull-down '0'	Default
GPIO0	Disable EDAC	R4	R8	Pull-up
GPIO17	Bypass Internal Boot Prom	R3	R7	Pull-down
GPIO62	Enable Memory Test	R2	R6	Pull-down
GPIO63	Redundant Memory Available	R1	R5	Pull-down
DSUTX	Copy ASW image/SPW default frequency	R23	R27	Pull-up
SPIM_MOS	Remote Access/Boot from Memory	R32	R35	Pull-down
SPIM_SCK	Boot Source 0	R31	R34	Pull-down
SPIM-SEL	Boot Source 1	R30	R33	Pull-down

Table 4: Bootstrap Resistor Settings

4.11 Debug Support Unit Interfaces

Program download and debugging to the processor is performed using the GRMON Debug Monitor tool from Frontgrade Gaisler ([RD4]). The GR716 microcontroller provides a UART based DSU interface for Debug and control of the processor by means of a host terminal, as represented in Figure 4-11.

Four control signals from the Debug Support Unit interface to the processor are implemented:

DSUTX	Debug UART Transmit
DSURX	Debug UART Receive
DSUEN	This signal is pulled high on the board to enable Debugging
DSUBRE	This signal is pulled low on the board

The DSUTX and DSURX signals are connected to the FTDI UART to USB converter chip, allowing easy connection to a host PC using a USB cable.

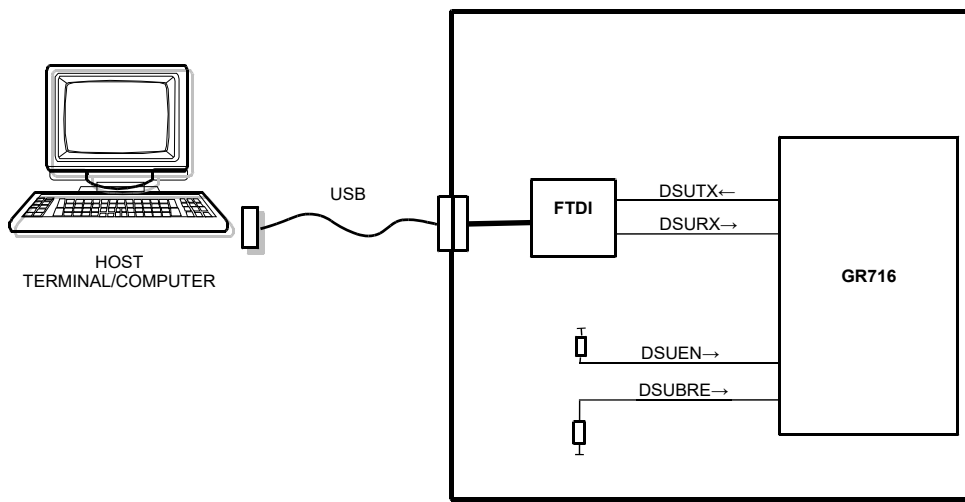

Figure 4-11: Debug Support Unit connections

4.12 Oscillators and Clock Inputs

The oscillator and clock scheme for the GR716-MINI Board is shown in Figure 4-12.

Two oscillator inputs are required: *CLK* for the main system clock, and *SPW_CLK* for the SpaceWire clock of the microcontroller.

To allow the GR716 Microcontroller to operate in a stand alone manner a soldered 20MHz crystal is installed on the board which connected to the Crystal oscillator interface for the GR716.

This generates a 20MHz output clock, *XO_OUT*, which is connected to the *CLK* and *SPW_CLK* inputs with zero-ohm resistors.

In an alternative scenario, it may be preferred to have a separate *CLK* or *SYS_CLK* to allow different frequencies to be used. In this case the 0R resistors can be removed, and instead the 'not-fitted' resistors be placed with zero-ohms to allow an external 3.3V LVCMOS oscillator input to provided via the expansion connector.

For more details of the internal Crystal Oscillator, PLL structure and clock gating features of the GR716, please refer to sections 9 and 10 of [RD1].

A separate 12 MHz crystal is required for the FTDI interface IC.

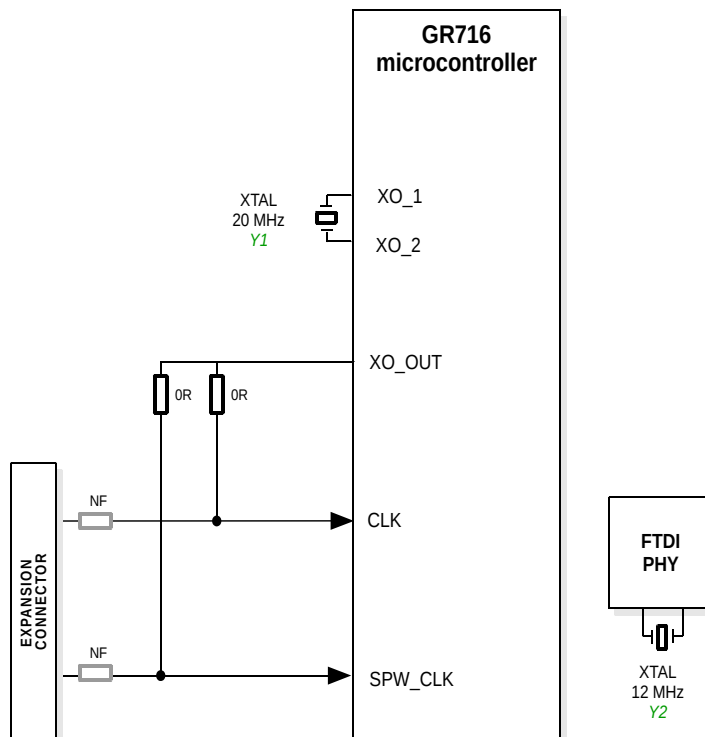

Figure 4-12: Board level Clock Distribution Scheme

4.13 Power Supply and Voltage Regulation

The power configuration is shown in Figure 4-13.

On this board, the microcontroller is configured to operate from a single +3.3V power rail. The VDD_CORE (1.8V) is generated by a LDO regulator inside the GR716 itself.

To allow the board to be powered from the +5V supply provided on a standard USB connector/cable, a LMZ21701 micro Point-of-Load regulator is included on the board which generates the 3.3V for the rest of the GR716-MINI board.

In an alternative scenario, when the GR716-MINI board is installed on an Expansion board or Motherboard, it is intended that the Motherboard should generate a regulated 3.3V supply and provide this via the Expansion connector.

In this configuration, the jumper JP1 should be removed to disconnect the USB cable voltage, and the regulator is disabled by pulling its Enable signal low with the MB pin on the expansion connector

Note: it is not the intention that the on-board POL regulator is used to provide significant current toward other loads on the Expansion Board/Motherboard.

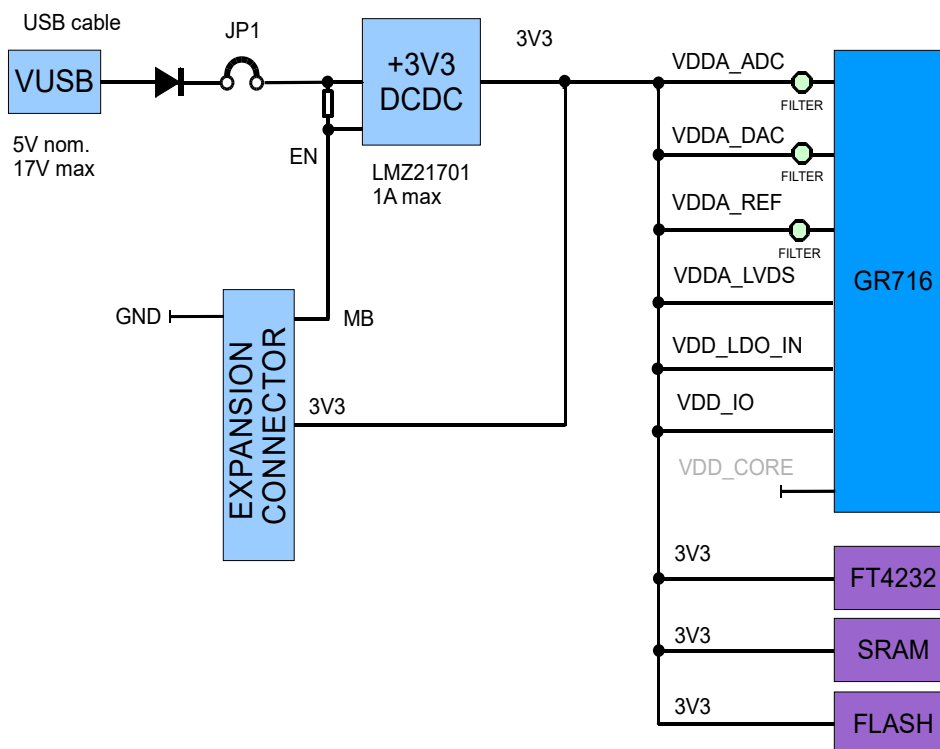

Figure 4-13: Power Regulation Scheme

4.14 Reset Circuit and Button

The GR716 microcontroller includes an internal RESET circuit with Brown-out detector to reset the processor and its peripherals (see section 8 of [RD1]).

The resulting low reset signal is present on the microcontroller pin *RESET_OUT_N*. This signal is connected to the expansion connector, P1.

To provide a manual reset of the microcontroller, a miniature push button switch, S1, is provided on the PCB which connects to the *RESET_IN_N* signal.

This signal is also present on the expansion connector P1, and can be driven from an external circuitry if required.

4.15 Watchdog

The GR716 microcontroller includes an internal Watchdog timer function which can be used for the purpose of generating a system reset in the event of a software malfunction or crash. Please refer to [RD1].

5 SETTING UP AND USING THE BOARD

The board is provided with a default configuration set by bootstrap resistors. These define the configuration at power on of the board

Other configurations may be defined by the user, by installing/removing the bootstrap resistors.

For additional information, refer to [RD2] and for information about the Bootstrap signals, refer to section 4.10.

There is one miniature jumper on the board as shown in Table 5.

Jumper	Comment
JP1	<p>Install to allow 5V supply from USB cable to provide power to the board.</p> <p>Remove if board is installed on a motherboard and +3V3 power is provided from the carrier board via connector P1</p>

Table 5: Default Setting of Jumpers

To operate the board stand alone on the bench top, connect the board with a Micro USB cable to a USB port on a host computer/laptop. This provides +5V supply to the board.



ATTENTION! To prevent damage to board, please ensure that the correct power supply voltage and polarity is used with the board.

Do not exceed +17V at the power supply input, as this may damage the board.

The POWER LED should be illuminated indicating that the power supply is present and the board is generating the +3.3V it requires.

Upon power on, the Processor will start copy a ASW container from beginning at the memory location 0x02000000, which is the start of the external SPI FLASH. If the SPI FLASH is 'empty' or no valid program is installed, the first executed instruction will be invalid, and the processor will halt with an ERROR condition.

To perform program download and software debugging on the hardware it is necessary to use the Frontgrade Gaisler GRMON3 debugging software, installed on a host PC (as represented in Figure 4-11). Please refer to the GRMON3 documentation for the installation of the software on the host PC (Linux or Windows), and for the installation of the associated hardware dongle.

To perform software download and debugging on the processor, a link from the Host computer to the DSU interface of the board is necessary. As described in section 4.11 this is achieved via the FTDI USB interface.

Program download and debugging can be performed in the usual manner with GRMON3. More information on the usage, commands and debugging features of GRMON3, is given in the GRMON3 Users Manuals and associated documentation, [RD4].

6 INTERFACES AND CONFIGURATION

6.1 List of Connectors

Name	Function	Type	Description
J1	FTDI-USB	USB-Micro-B	Configurable serial to USB I/F via FTDI chip according section 4.7
J2	ANALOG-1	MMCX-jack	Coaxial connector ADC-1 or DAC-1
J3	ANALOG-2	MMCX-jack	Coaxial connector ADC-2 or DAC-2
J4	ANALOG-3	MMCX-jack	Coaxial connector ADC-3 or DAC-3
J5	ANALOG-4	MMCX-jack	Coaxial connector ADC-4 or DAC-4
PI	EXPANSION	HIROSE_FX11-80p	Expansion connector

Table 6: List of Connectors

Pin	Name	Comment
1	VBUS	+5V (from external host)
2	DM	Data Minus
3	DP	Data Plus
4	ID	Not used
5	DGND	Ground

Table 7: J1 USB type Micro B connector – FTDI Serial Link

Pin	Name	Comment
Inner	ANALOG	Refer to section 4.8
Outer	AGND	Ground

Table 8: J2,J3,J4,J5 MMCX miniature coax connectors

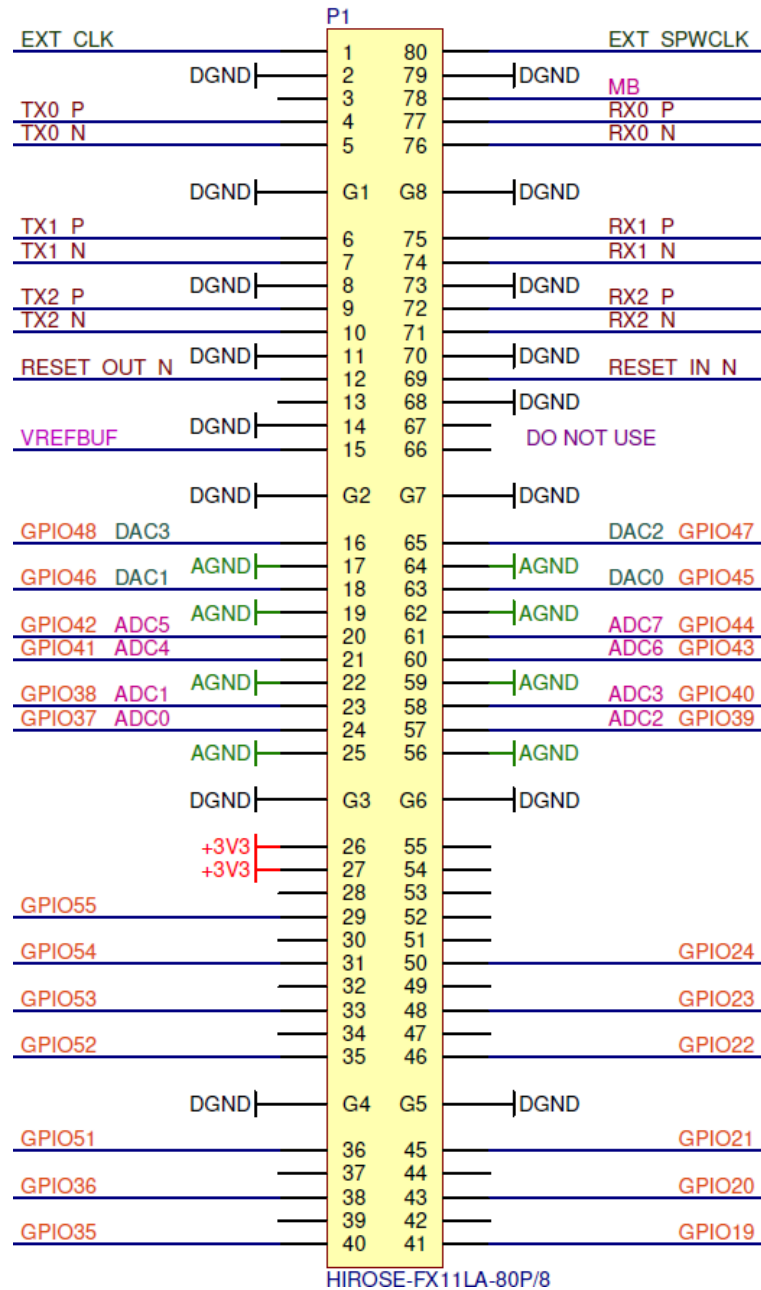

Table 9: Expansion connector P1 Pin-out

6.2 List of Oscillators, Switches and LED's

Name	Function	Description
Y1	USB-XTAL	20 MHz, SMD soldered
Y2	FTDI-XTAL	12 MHz, SMD soldered

Table 10: List and definition of Oscillators and Crystals

Name	Function	Description
D1	POWER	3.3V power

Table 11: List and definition of PCB mounted LED's

Name	Function	Description
S1	RESET	Push button RESET switch

Table 12: List and definition of Switches

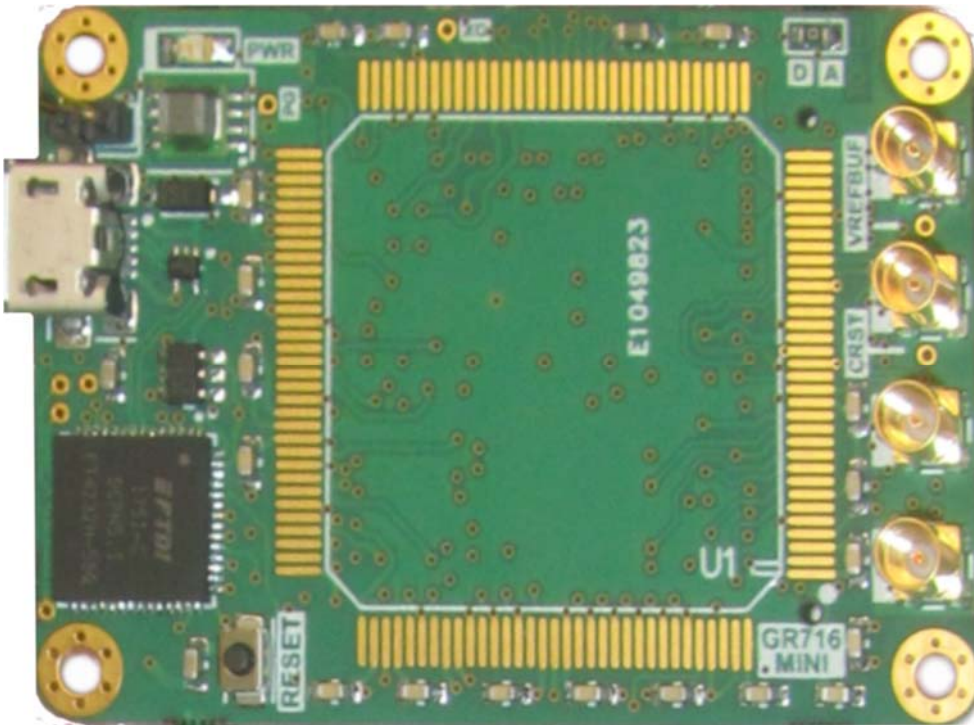

Figure 6-3: PCB Top View (Photo)

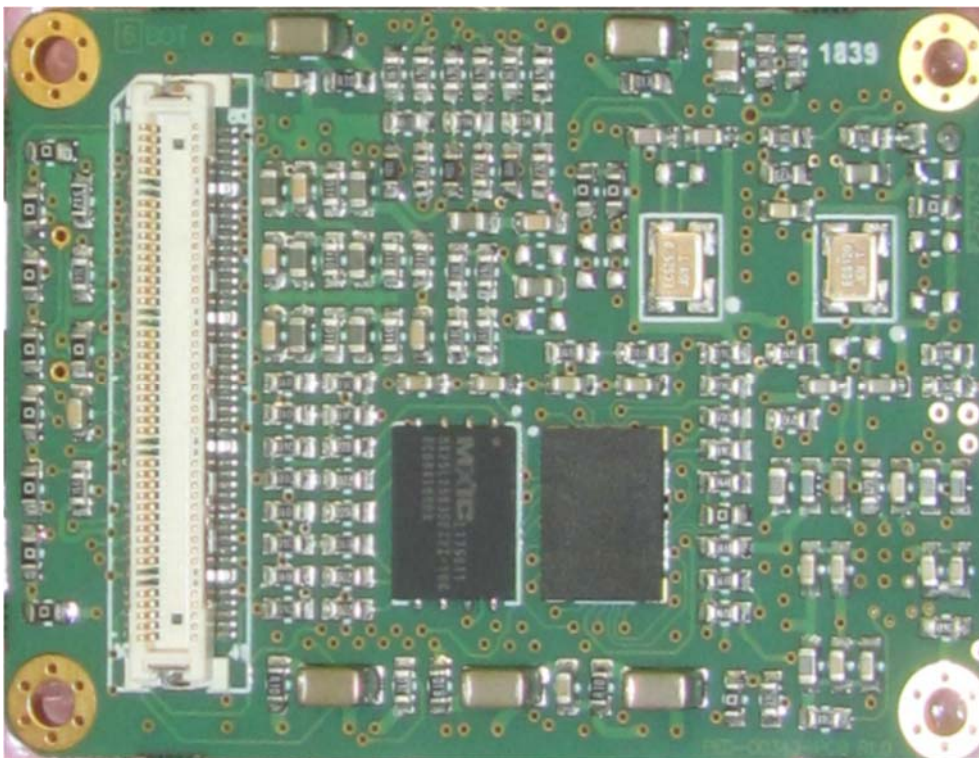

Figure 6-4: PCB Bottom View (Photo)

REVISION INFORMATION

Issue	Date	Section / Page	Description
0.0	2018-10-18	All	Draft Issue
0.1	2018-11-25	4.10	Updated default bootstraps to match SPI Flash boot
		5	Corrected start address
		4.2	Swapped figure 4-3
0.2	2019-05-02	All	Corrected frequency of crystal and default bootstrap
1.0	2023-10-26	All	Updated company name and document template
		4.6	Handling instructions for LVDS added
1.1	2024-12-19	Section 4.2	Carrier board picture is removed since it is not possible to procure.

Frontgrade Gaisler AB
Kungsgatan 12
411 19 Göteborg
Sweden
www.frontgrade.com/gaisler
sales@gaisler.com
T: +46 31 7758650

Frontgrade Gaisler AB reserves the right to make changes to any products and services described herein at any time without notice. Consult the company or an authorized sales representative to verify that the information in this document is current before using this product. The company does not assume any responsibility or liability arising out of the application or use of any product or service described herein, except as expressly agreed to in writing by the company; nor does the purchase, lease, or use of a product or service from the company convey a license under any patent rights, copyrights, trademark rights, or any other of the intellectual rights of the company or of third parties. All information is provided as is. There is no warranty that it is correct or suitable for any purpose, neither implicit nor explicit.

Copyright © 2024 Frontgrade Gaisler AB